



PROVEN PROCESS

DISCOVERY

1

We begin by asking questions to understand your firm's values, history, and current project needs. Our goal is to better understand our customers and set the stage for a long-term relationship. Our team will thoroughly review any preliminary details of your project. We apply these principles no matter the scope of work.

2

DESIGN DEVELOPMENT

We take a stepwise approach to move from an early design to a fully completed design. Our team will work to provide up-front value engineering for your project, involving detail discovery and analysis to create mutually beneficial results that saves your client money and adds layers of efficiencies later on.



PRELIMINARY & FINAL PRICING

3

We will steadily progress in our understanding of what the client wants or the vision you are trying to achieve. Through this phase, we will work toward bringing a preliminary price to a firm price. We will create a Purchase Order and once final drawings are approved, we will submit final pricing.

4

FINAL DESIGN & DRAWINGS

We will review client designs in great detail to ensure that every aspect of your order or project is planned for, and covered before production. With your approved drawings, we will move through our approval process and send you an official Sales Order. We look to supply our production team with high quality drawings so that they can provide an excellent finished product.

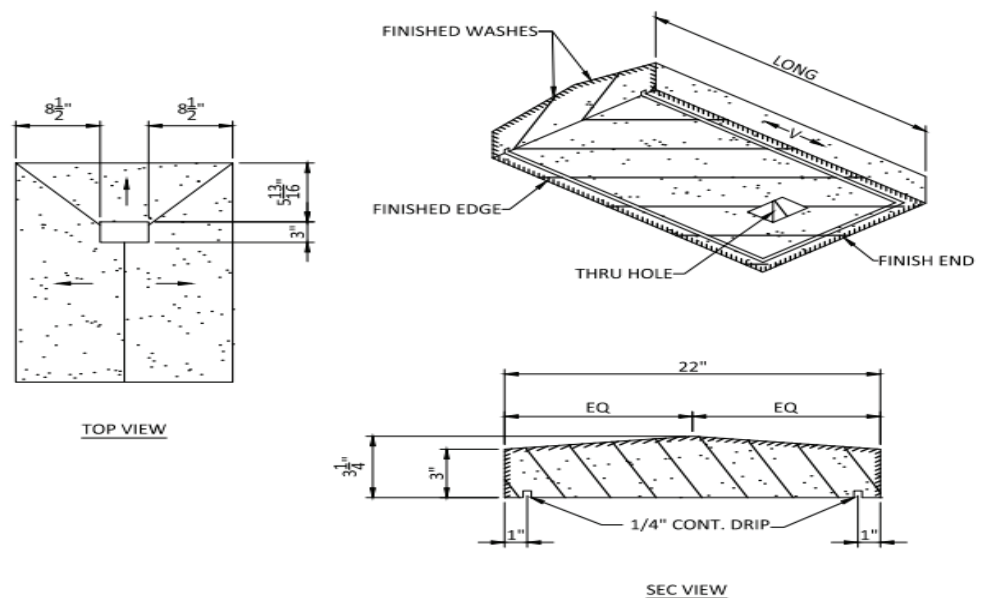

PRODUCTION & FULFILLMENT

5

Our skilled stone fabrication team works to create the parts per order or to project specifications. We effectively transform our stone from raw material to a finished product while maximizing efficiencies and stone yield. Your current project is complete and we look forward to working on your next order or project. We desire to maintain a solid partnership with your firm and create a long-lasting equitable relationship.